



Finelock™ M48
System Scaffold Catalogue

Finelock M48 System Scaffold



Wenma Scaffolding, Your Solution Partner

Wenma is a manufacturer, distributor, rental supplier and scaffolding contractor of high-quality scaffolding solutions. Our entire team is dedicated to understanding the needs and requirements of scaffolding professionals in the construction, oil and gas, mining, shipbuilding, and other industries. This allows us to provide advice and expertise for every scaffolding project worldwide and find the best solutions. This also includes professional training and technical engineering services as additional services.

Guided by the mission, with its innovative spirit and extensive experience, Wenma products are designed and built to keep scaffolders safe at all times. At the same time, our Finelock M48 modular scaffolding system is highly flexible, maintain the highest standards of durability and sustainability and is used by clients around the world for various projects. For more information about Wenma, our scaffolding products and services, please visit www.iwenma.com.



Technical Engineering Support, Whole Project Solutions

The engineering team at Wenma is happy to support you with several scaffolding and technical services to make your project successful including creating designs, drawings and statical calculations, technical support whenever you need it, visits to your project site as well as the full planning of your project from start to end.

Finelock M48 System Scaffold



Makes Your Work Much Easier Than Ever

Finelock M48 System Scaffold is a high-quality modular scaffolding system that allows you to work safely for decades with hardly any maintenance costs. No matter what project is on your agenda, Finelock M48 System Scaffold provides you with the necessary flexibility.

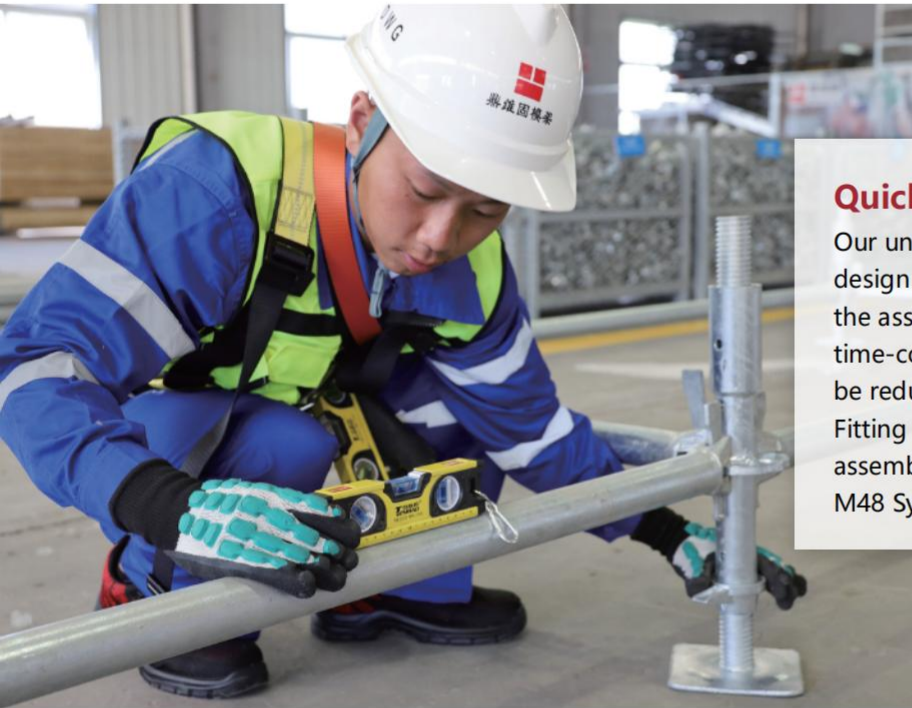

Quick and Easy to Save Man-Hour

Our unique Finelock M48 Rossette connection design and prefabricated component system make the assembly process quick and easy, saving time-consuming measuring work, so labor costs can be reduced by up to 70% compared to Tube and Fitting Scaffolding. Only 3 scaffolders are needed to assemble a simple scaffolding structure with Finelock M48 System Scaffold.

Simple to Assemble with Less Components

When you are assembling and dismantling scaffolding, you need to put in a lot of physical effort. You don't want to spend your energy measuring and thinking about which scaffolding component should go where, only to find out that they don't fit together as expected. Finelock M48 saves you this trouble. You can easily build a safe and stable scaffold with only a couple of basic prefabricated components.



Finelock M48 System Scaffold

High Safety Standard, Serve Chemical, Oil & Gas Industries

When you work in chemical, power plants or oil & gas, you are confronted with the individual requirements of the respective operator. Especially in such challenging environments, the safety of all participants always comes first. With specially designed accessories, Finelock M48 ensures that you are always safe, even in demanding environments such as chemical plants or offshore areas. This is supported by accessories such as anti-slip decks, gap fill decks or safety guard rails, safety gate and more.





Scaffolding Project in Shipbuilding Industry



Finelock M48 System Scaffold

One System Infinite Application

In the real world, we may encounter various project requirements. Sometimes you need to erect an access platform at a particularly great height. In another project, you may need to build scaffolding for irregularly shaped objects or bridge pipes. The project may be in the construction sector, or it may be in the industrial sector. Finelock M48 System Scaffold is designed and prefabricated with different customized components that can easily meet the needs of various applications.

Compatible with Other Leading Scaffold Systems

Finelock M48 is tested for compatibility with scaffolding systems from other leading manufacturers. This allows you to remain flexible while retaining the value of your current stock. Our engineering team has prepared the Finelock M48 Technical Manual for your convenience, and is always ready to assist you with any engineering design. With the mixing approval of Finelock M48, you do not have to make elaborate static calculations, but can use your material freely.



Finelock M48 System Scaffold



Designed for Scaffolding and Shoring

Finelock M48 is not only an excellent scaffolding system, but it can also be used as a versatile shoring system for lighter load. For heavier load projects, you simply replace the M48 Vertical Standards with M60 Vertical Standards, which can increase the load-bearing capacity of the shoring structure by several times. Our engineers have taken into consideration the compatibility between the two systems in the product design, so most of the components can be used interchangeably, which reduces the difficulty of project management and enhances the value of your investment.



Quality and Safety from Controlled Process

Safety and Efficiency start from design and quality products. To ensure that we are able to deliver our scaffolding systems with the highest quality standards, from R&D to all the production process, we make it happen all in our own facilities. Our quality assurance process certified by ISO9001 starts with the selection of certified raw materials and continues throughout the entire production chain until the goods are safely loaded for shipping and transportation. Hot-dip galvanizing finish ensures that our scaffold materials can be used safely for decades.

Finelock M48 System Scaffold



Trainings & Seminars Accredited by CISRS

The right planning, the correct handling, and the ability to know what to do in case of an emergency are equally important as high-quality scaffolding systems. That is why Wenma offers regular trainings as well as special trainings for scaffolders, engineers or your external partners. We are proud to have received CISRS accreditation for our training centers in China, which allows us to provide world-class scaffolding safety training to our clients and workers. Finelock M48 System Scaffold and Fineshore M60 Shoring System training course covered by CISRS and Simian Skills.



Independently Tested and Approved

Certificates and approvals from independent institutes help you to determine that a scaffold meets your standards of safety and quality. We always put the quality of our Scaffolding and Shoring systems first. Sourcing our raw materials only from trusted partners plays a big part in this, more importantly, continuous professional testing is required from raw materials to product performance to ensure that every Scaffolding and Shoring component meets quality standards. We have our own physical, chemical, and mechanical lab accredited by CNAS, meanwhile, our products are also certified and tested by independent institutions such as TÜV, SGS and CIDB. In addition, we have regular audits carried out by independent third parties such as NASC - English National Access & Scaffolding Confederation.





Component Identification

Finelock M48 System Scaffold

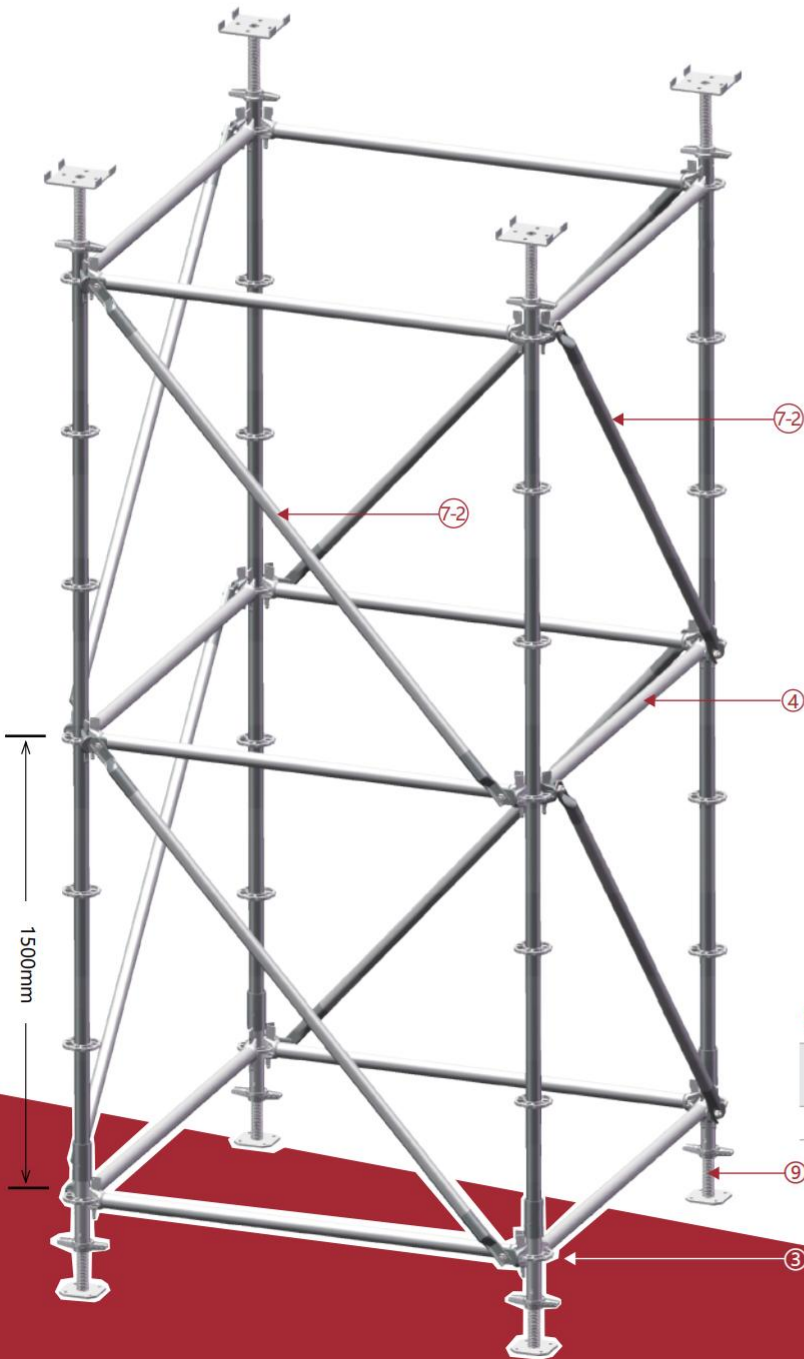

7-2. Vertical Bay Brace

Part No.	Weight (kg)	Packaging	
		QTY	Type
M60VBB2415	8.26	198	Rack
M60VBB2115	7.66	198	Rack
M60VBB1815	7.09	198	Rack
M60VBB1515	6.57	198	Rack
M60VBB1215	6.11	198	Rack
M60VBB0915	5.73	198	Rack
M60VBB0615	5.46	198	Rack

4. Horizontal Ledger

Part No.	Weight (kg)	Packaging	
		QTY	Type
M60HL30	10.20	247	Rack
M60HL24	8.26	247	Rack
M60HL21	7.28	247	Rack
M60HL18	6.31	247	Rack
M60HL15	5.34	247	Rack
M60HL12	4.36	247	Rack
M60HL09	3.39	238	Rack
M60HL06	2.42	512	Rack Bin
M60HL03	1.45	600	Rack Bin

3. Base Collar (M48)



Part No.	Weight (kg)	Packaging	
		QTY	Type
M48BC	2.14	246	Rack Bin
M48BC_S	1.48	660	Rack Bin

9. Base Jack (M48)

Part No.	Weight (kg)	Packaging	
		QTY	Type
M48ABJ	3.70	270	Rack



Component Identification

Finelock M48 System Scaffold

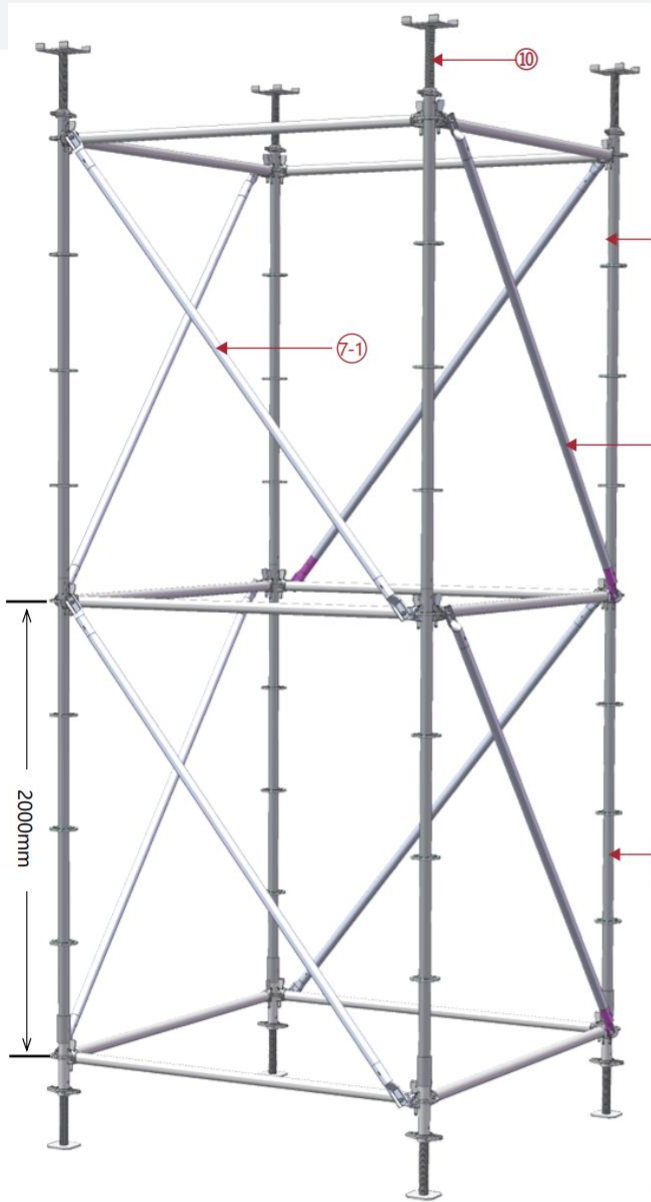

10. U Head Jack (M48)

Part No.	Weight (kg)	Packaging	
		QTY	Type
M48AUH	4.80	180	Rack



1. Vertical Standard (M48)

Part No.	Weight (kg)	Packaging	
		QTY	Type
M48VS300	13.79	110	Rack
M48VS200	9.20	110	Rack
M48VS150	6.90	110	Rack
M48VS100	4.60	110	Rack
M48VS50	2.30	192	Rack Bin

7-1. Vertical Bay Brace

Part No.	Weight (kg)	Packaging	
		QTY	Type
M48VBB3020	10.19	198	Rack
M48VBB2420	9.03	198	Rack
M48VBB2120	8.49	198	Rack
M48VBB1820	8.00	198	Rack
M48VBB1520	7.55	198	Rack
M48VBB1220	7.17	198	Rack
M48VBB0920	6.90	198	Rack

36. Spigot (M48)

Part No.	Weight (kg)	Packaging	
		QTY	Type
M48S	0.40	1000	Rack Bin

2. Vertical Standard (M48) w/Spigot

Part No.	Weight (kg)	Packaging	
		QTY	Type
M48VS300S	14.19	110	Rack
M48VS200S	9.60	110	Rack
M48VS150S	7.30	110	Rack
M48VS100S	5.00	220	Rack
M48VS50S	2.70	330	Rack



Component Identification

Finelock M48 System Scaffold

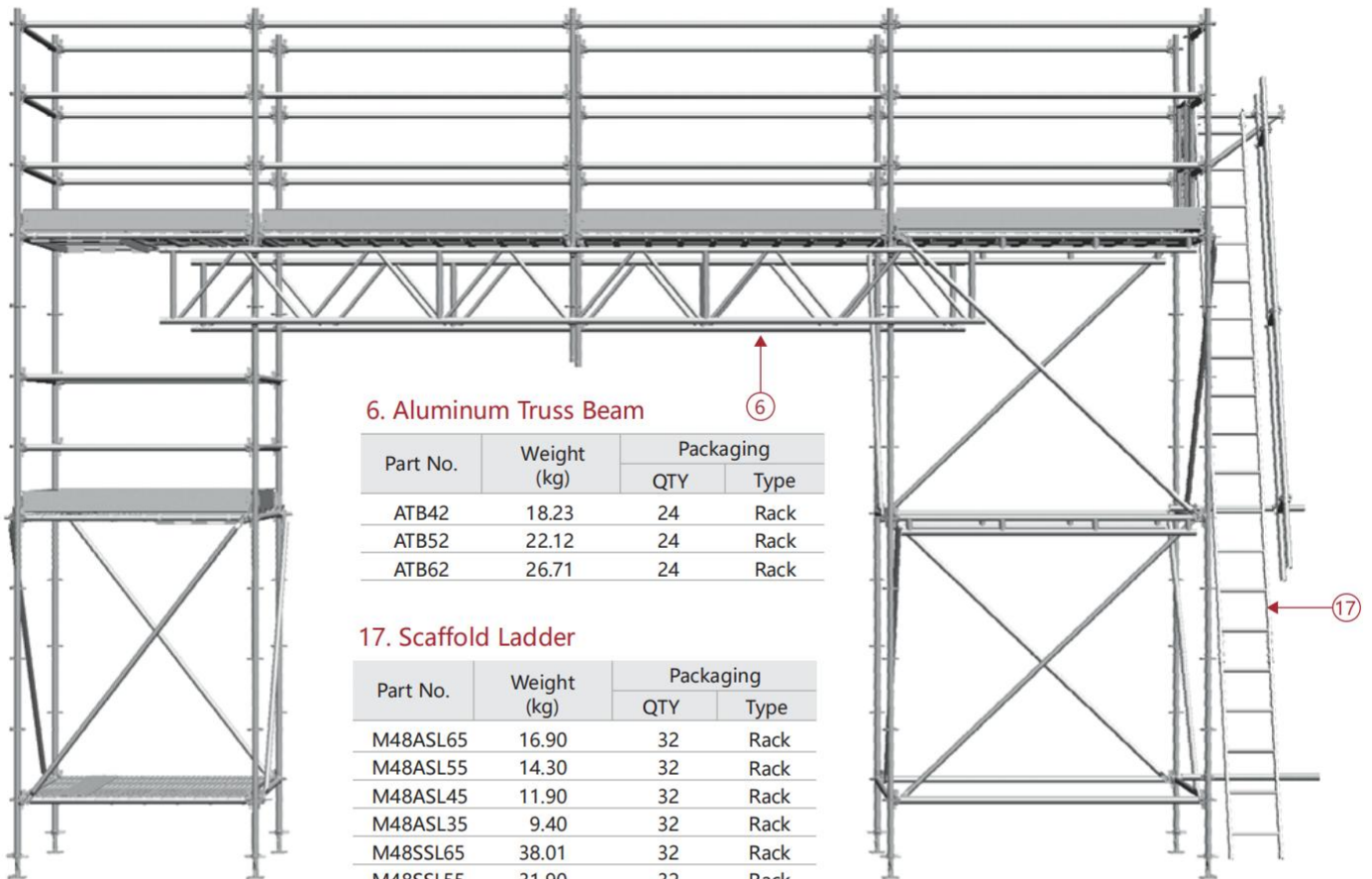

6. Aluminum Truss Beam

Part No.	Weight (kg)	Packaging	
		QTY	Type
ATB42	18.23	24	Rack
ATB52	22.12	24	Rack
ATB62	26.71	24	Rack

17. Scaffold Ladder

Part No.	Weight (kg)	Packaging	
		QTY	Type
M48ASL65	16.90	32	Rack
M48ASL55	14.30	32	Rack
M48ASL45	11.90	32	Rack
M48ASL35	9.40	32	Rack
M48SSL65	38.01	32	Rack
M48SSL55	31.90	32	Rack
M48SSL45	26.23	32	Rack
M48SSL35	20.57	32	Rack

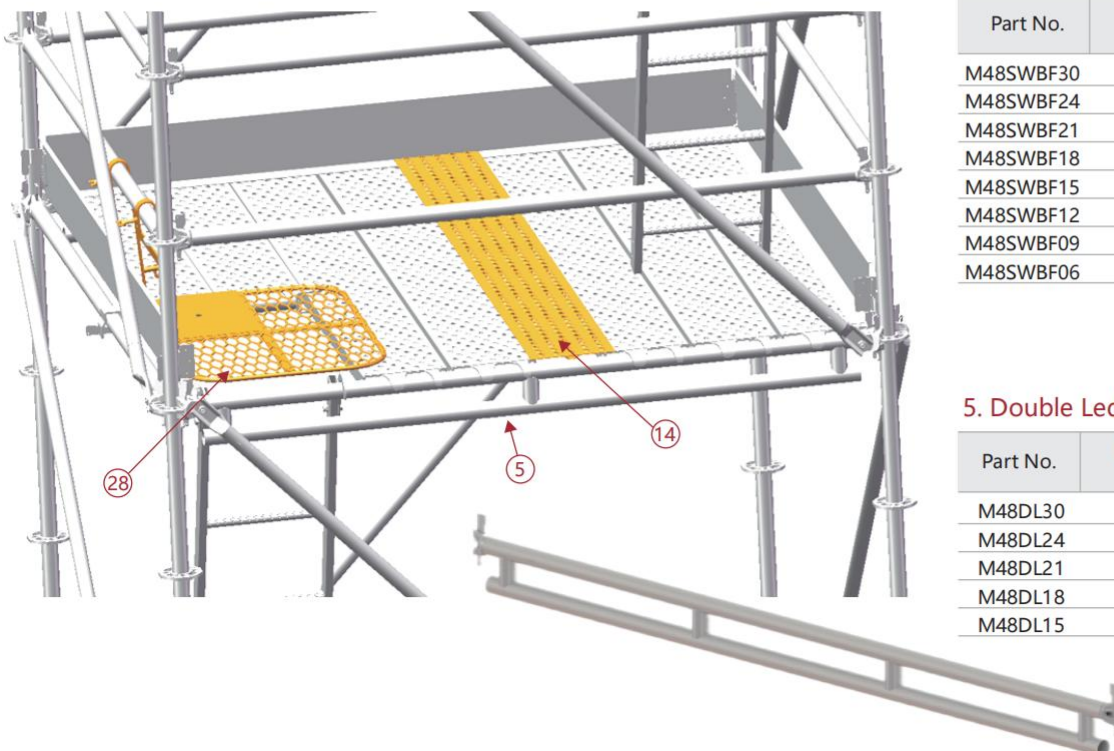

14. Steel Walkboard Filler

Part No.	Weight (kg)	Packaging	
		QTY	Type
M48SWBF30	10.00	400	Rack
M48SWBF24	7.88	400	Rack
M48SWBF21	6.83	400	Rack
M48SWBF18	5.77	400	Rack
M48SWBF15	4.72	400	Rack
M48SWBF12	3.66	400	Rack
M48SWBF09	2.60	500	Rack Bin
M48SWBF06	1.55	500	Rack Bin

5. Double Ledger

Part No.	Weight (kg)	Packaging	
		QTY	Type
M48DL30	18.72	88	Rack
M48DL24	15.16	88	Rack
M48DL21	13.15	88	Rack
M48DL18	11.37	88	Rack
M48DL15	9.35	88	Rack

Component Identification

Finelock M48 System Scaffold

8. Side Bracket (M48)

Part No.	Weight (kg)	Packaging	
		QTY	Type
M48SB12	11.57	25	Rack
M48SB09	7.76	40	Rack Bin
M48SB06	6.13	63	Rack Bin
M48SB03	4.00	100	Rack Bin

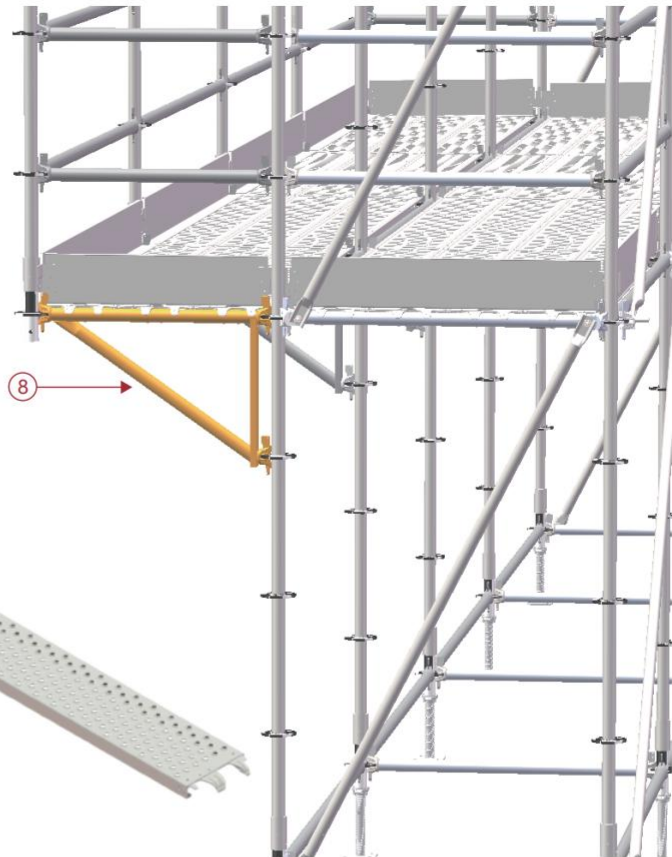

11. Steel Plank

Part No.	Weight (kg)	Packaging	
		QTY	Type
M48SP_30	17.72	72	Rack
M48SP_24	14.42	72	Rack
M48SP_21	12.76	72	Rack
M48SP_18	11.11	72	Rack
M48SP_15	9.46	72	Rack
M48SP_12	7.80	72	Rack
M48SP_09	6.15	72	Rack
M48SP_06	4.50	72	Rack

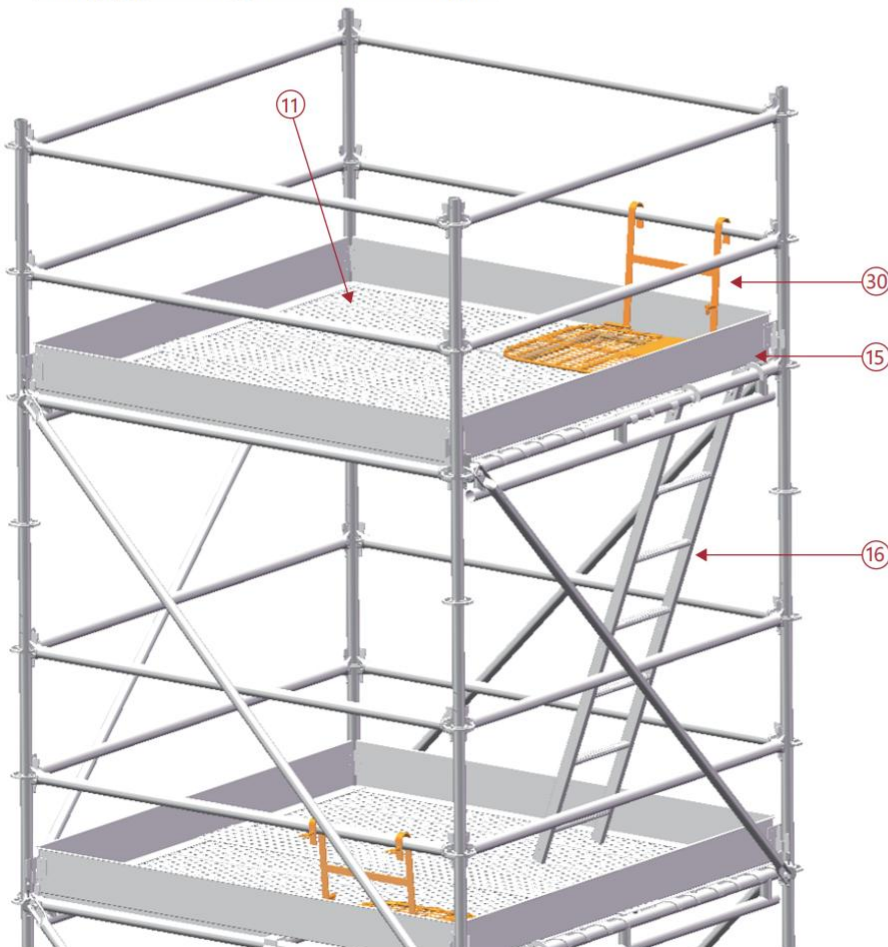
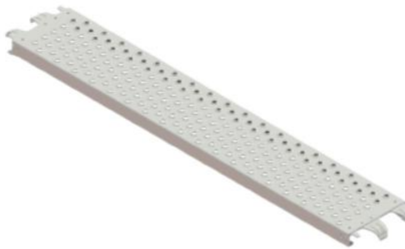

30. Access Trap Door

Part No.	Weight (kg)	Packaging	
		QTY	Type
M48ATD	14.23	20	Rack Bin

15. Toeboard

Part No.	Weight (kg)	Packaging	
		QTY	Type
M48TB30	9.93	320	Rack
M48TB24	7.96	320	Rack
M48TB21	6.98	320	Rack
M48TB18	6.00	320	Rack
M48TB15	5.02	320	Rack
M48TB12	4.03	320	Rack
M48TB09	3.05	320	Rack
M48TB06	2.07	400	Rack

16. Access Ladder

Part No.	Weight (kg)	Packaging	
		QTY	Type
M48AL21	8.09	32	Rack
M48AL15	5.83	32	Rack

Component Identification

Finelock M48 System Scaffold



12. Steel WalkBoard

Part No.	Weight (kg)	Packaging	
		QTY	Type
M48SWB_30	18.90	65	Rack
M48SWB_24	15.27	65	Rack
M48SWB_21	13.55	65	Rack
M48SWB_18	11.72	65	Rack
M48SWB_15	9.92	65	Rack
M48SWB_12	8.17	65	Rack
M48SWB_09	6.45	65	Rack
M48SWB_06	4.81	65	Rack

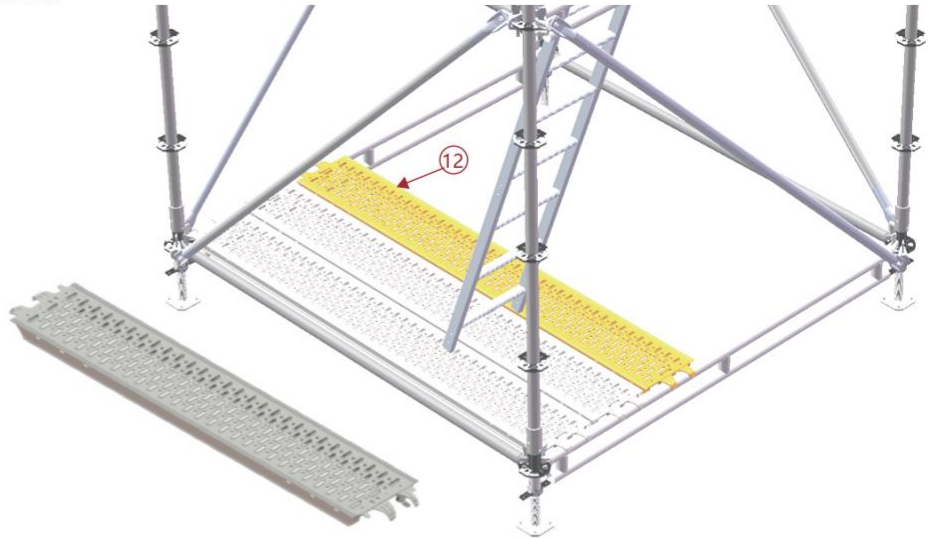

13. Access Walkboard

Part No.	Weight (kg)	Packaging	
		QTY	Type
M48AWB18_09	21.40	19	Rack
M48AWB18_06	13.86	23	Rack

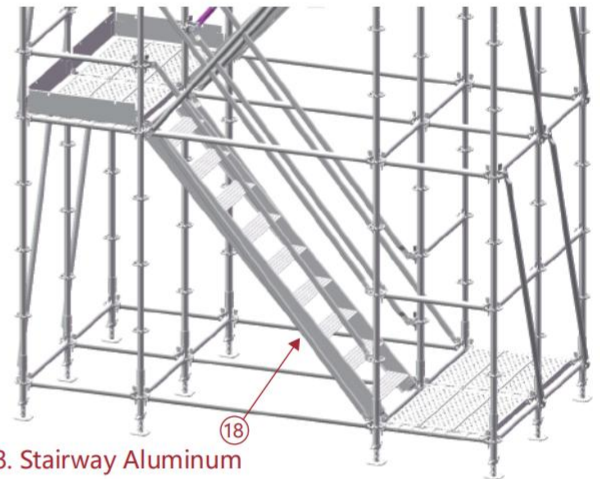
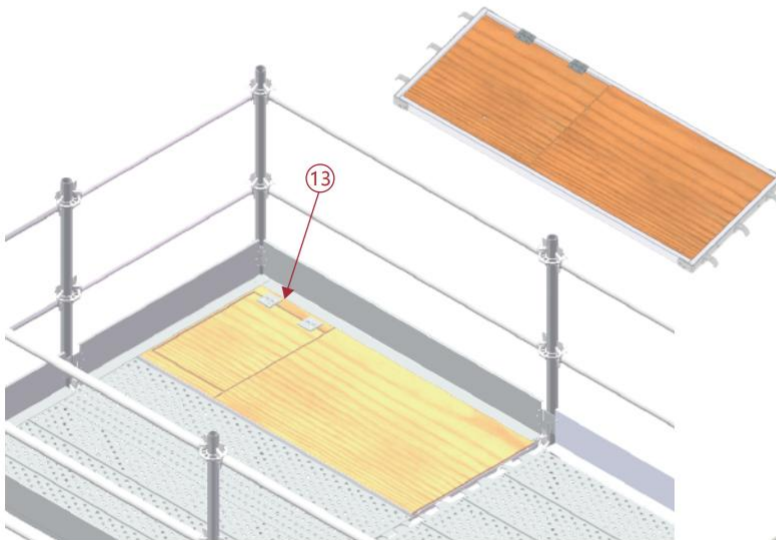

18. Stairway Aluminum

Part No.	Weight (kg)	Packaging	
		QTY	Type
M60SW2420_AL650	22.59	8	Rack
M60SW2120_AL650	22.68	8	Rack
M60SW1820_AL650	20.84	8	Rack

34. Platform Stairway Post

Part No.	Weight (kg)	Packaging	
		QTY	Type
M48PSP	5.79	110	Rack

19. Platform Stairway Aluminum

Part No.	Weight (kg)	Packaging	
		QTY	Type
M48PSW3020_AL750	33.47	6	Rack
M48PSW2420_AL750	29.11	6	Rack

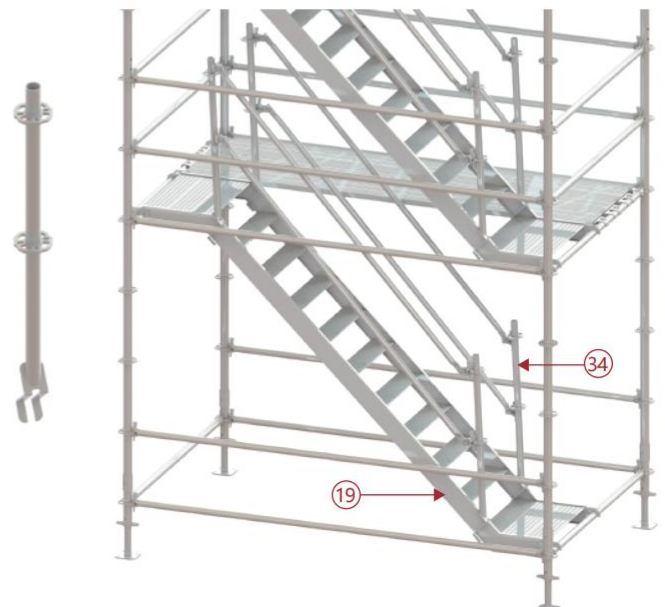

Component Identification

Finelock M48 System Scaffold

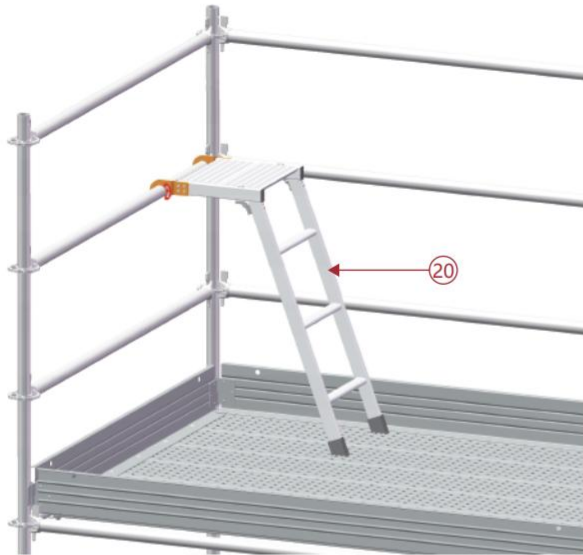

21. Suspended Standard Clamp

Part No.	Weight (kg)	Packaging	
		QTY	Type
M48SSC	8.84	80	Rack Bin

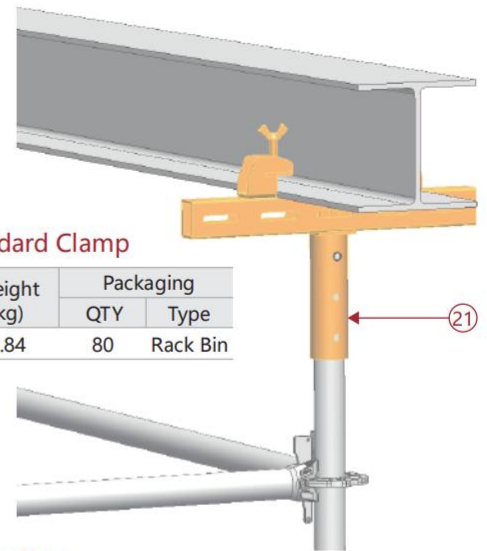

20. Aluminum Scaffolders Step

Part No.	Weight (kg)	Packaging	
		QTY	Type
M48ASS	5.94	18	Rack

23. Cantilever Clamp

Part No.	Weight (kg)	Packaging	
		QTY	Type
M48CC	9.81	80	Rack

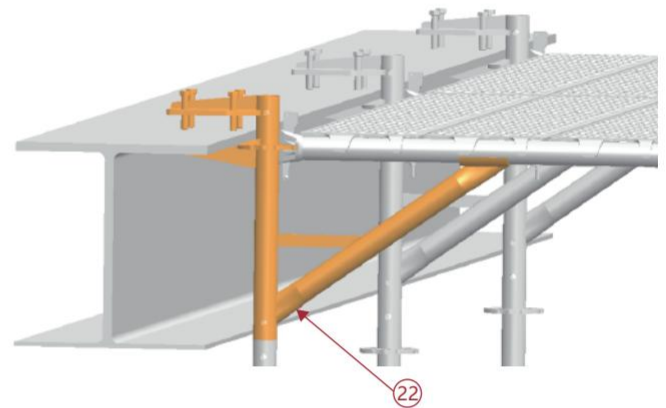
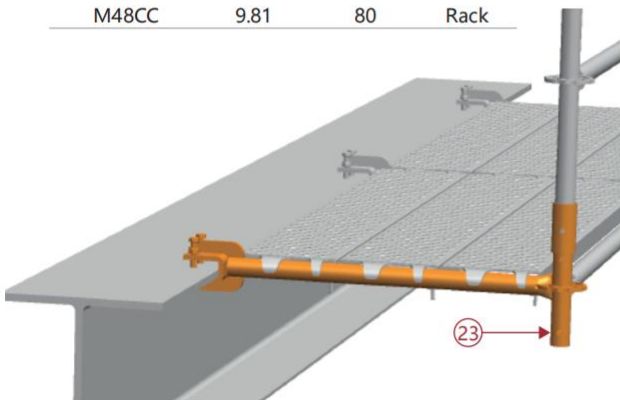

22. Beam Side Clamp

Part No.	Weight (kg)	Packaging	
		QTY	Type
M48BSC	6.95	80	Rack Bin



25. Transom Clamp

Part No.	Weight (kg)	Packaging	
		QTY	Type
M48TC_S	0.48	2000	Rack Bin
M48TC_D	0.57	2000	Rack Bin



Component Identification

Finelock M48 System Scaffold

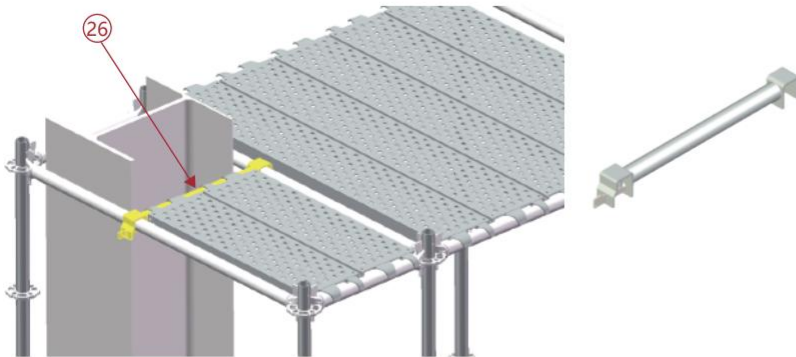

26. Transom Ledger to Ledger

Part No.	Weight (kg)	Packaging	
		QTY	Type
M48TLL24	9.37	154	Rack
M48TLL21	8.31	154	Rack
M48TLL18	7.25	154	Rack
M48TLL15	6.19	154	Rack
M48TLL12	5.13	154	Rack
M48TLL09	4.04	154	Rack



27. Transom Board to Board

Part No.	Weight (kg)	Packaging	
		QTY	Type
M48TBB75	4.21	154	Rack
M48TBB50	3.37	150	Rack Bin
M48TBB25	2.52	300	Rack Bin

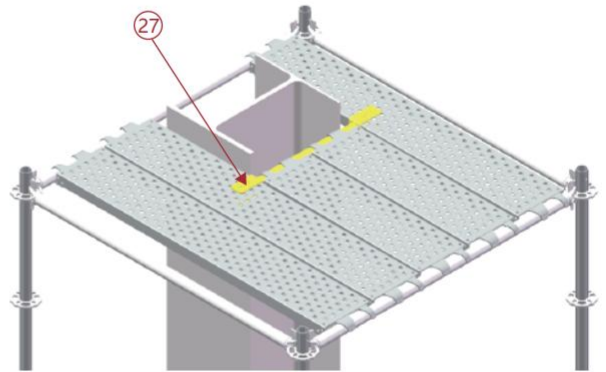

28. Transom Ledger to Board

Part No.	Weight (kg)	Packaging	
		QTY	Type
M48TLB75	3.98	154	Rack
M48TLB50	3.17	150	Rack Bin
M48TLB25	2.36	300	Rack Bin

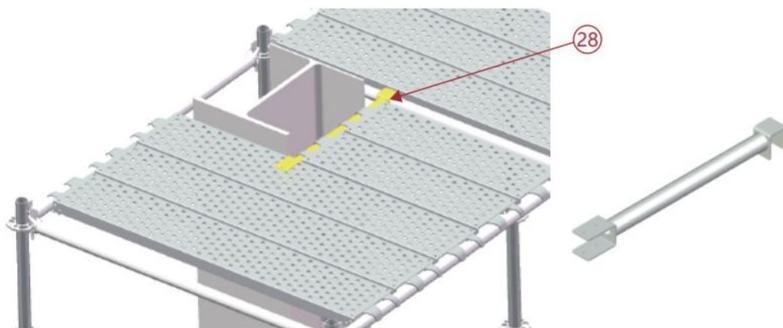

31. Corner Deck

Part No.	Weight (kg)	Packaging	
		QTY	Type
M48CD	10.69	80	Rack Bin

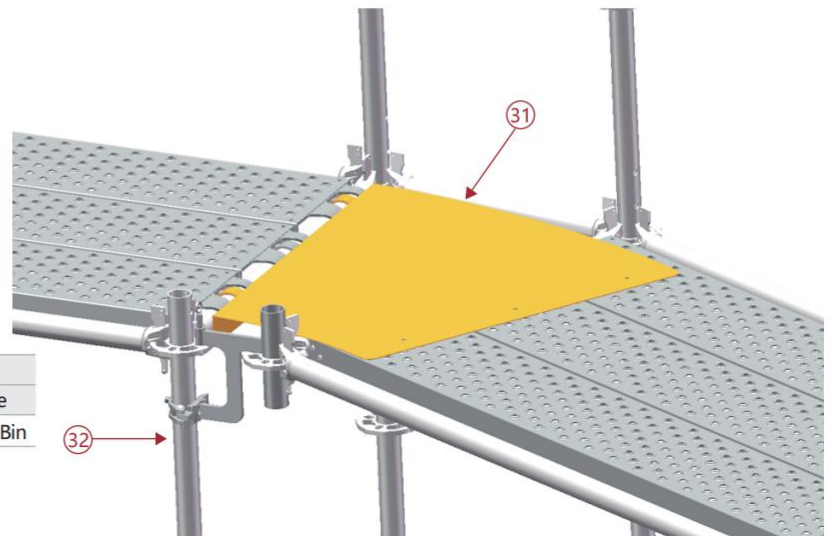

32. Corner Deck Adaptor

Part No.	Weight (kg)	Packaging	
		QTY	Type
M48CDA	3.04	300	Rack Bin



Component Identification

Finelock M48 System Scaffold



29. Adjustable Swing Gate

Part No.	Weight (kg)	Packaging	
		QTY	Type
M48ASG	14.23	16	Rack

33. Spigot Clamp

Part No.	Weight (kg)	Packaging	
		QTY	Type
M48SC	1.46	600	Rack Bin

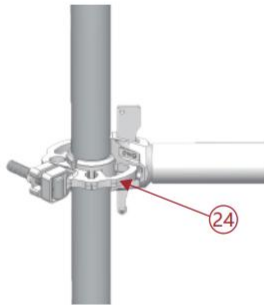

24. Rosette Wedge Coupler

Part No.	Weight (kg)	Packaging	
		QTY	Type
M48RWC	1.25	1000	Rack Bin

35-1. Wedge-Head Coupler Double

Part No.	Weight (kg)	Packaging	
		QTY	Type
M48WHC_D	0.96	800	Rack Bin

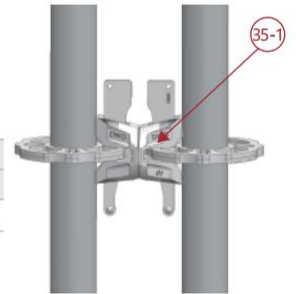

35-2. Wedge-Head Coupler Horizontal

Part No.	Weight (kg)	Packaging	
		QTY	Type
M48WHC_H	1.07	800	Rack Bin

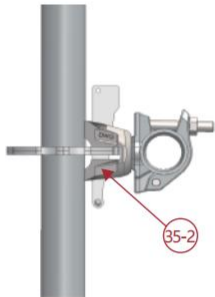

35-3. Wedge-Head Coupler Vertical

Part No.	Weight (kg)	Packaging	
		QTY	Type
M48WHC_V	1.07	800	Rack Bin

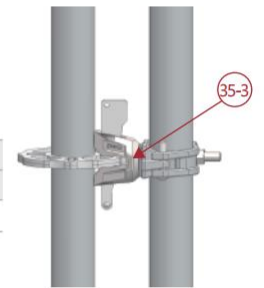

35-4. Wedge-Head Coupler Swivel

Part No.	Weight (kg)	Packaging	
		QTY	Type
M48WHC_S	1.26	800	Rack Bin

38. Scaffold Rack Bin

Part No.	Weight (kg)	Packaging	
		QTY	Type
SRB	84.00	/	/

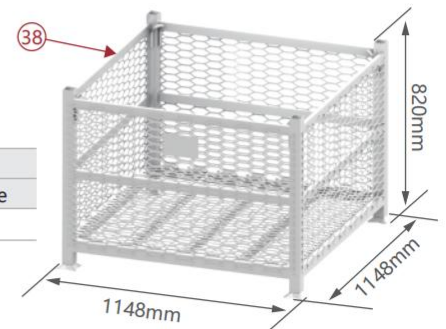

37. Scaffold Rack

Part No.	Weight (kg)	Packaging	
		QTY	Type
SR	48.50	/	/

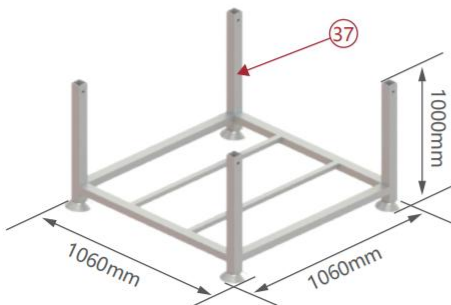

Finelock M48 System Scaffold



Expandable Components, Customized Solutions

A good scaffolding system adapts to the challenges you face. That's why we can customise Finelock M48 Scaffold components for you at any time. Chemical plants or refineries require high safety standards and therefore often require special solutions. No matter what challenges you want to tackle, our engineering team is at your service to facilitate the customisation of existing component products or the design of completely new component products especially for your application.

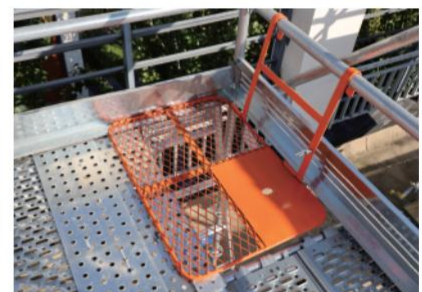

Racking & Packing

Finelock M48 System Scaffold

Vertical Standard (M48)

Part No.	Finelock M48 Components			Total Weight w/ Rack	Racking Dimension mm
	Weight (kg)	QTY/Rack (pcs)	Total weight (kg)		
M48VS300	13.79	110	1516.90	1565.40	3000x1060x1000
M48VS200	9.20	110	1012.00	1060.50	2000x1060x1000
M48VS150	6.90	110	759.00	807.50	1500x1060x1000
M48VS100	4.60	110	506.00	554.50	1060x1060x1000
M48VS50	2.30	192	441.60	525.60	1148x1148x820

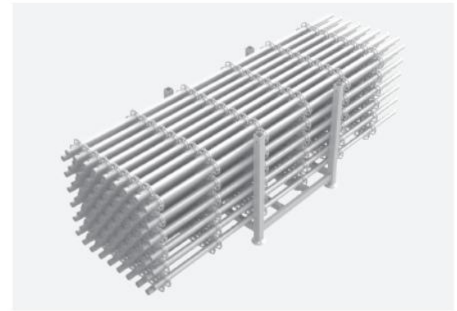

Vertical Standard (M48) w/Spigot

Part No.	Finelock M48 Components			Total Weight w/ Rack	Racking Dimension mm
	Weight (kg)	QTY/Rack (pcs)	Total weight (kg)		
M48VS300S	14.19	110	1560.90	1609.40	3150x1060x1000
M48VS200S	9.60	110	1056.00	1104.50	2150x1060x1000
M48VS150S	7.30	110	803.00	851.50	1650x1060x1000
M48VS100S	5.00	220	1100.00	1148.50	1150x1060x1000
M48VS50S	2.70	330	891.00	939.50	1650x1060x1000

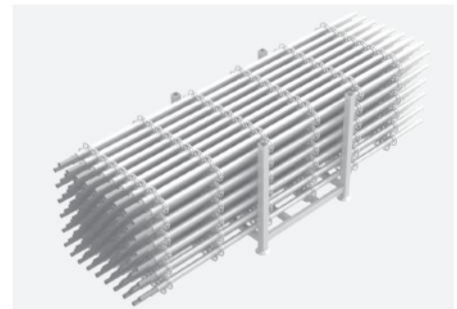

Base Collar (M48)

Part No.	Finelock M48 Components			Total Weight w/ Rack	Racking Dimension mm
	Weight (kg)	QTY/Rack (pcs)	Total weight (kg)		
M48BC	2.14	246	526.44	640.44	1148x1148x820
M48BC_S	1.48	660	976.80	1025.30	1148x1148x820

Horizontal Ledger



Part No.	Finelock M48 Components			Total Weight w/ Rack	Racking Dimension mm
	Weight (kg)	QTY/Rack (pcs)	Total weight (kg)		
M60HL30	10.20	247	2,519.40	2567.90	2950x1060x1000
M60HL24	8.26	247	2,040.22	2088.72	2350x1060x1000
M60HL21	7.28	247	1,798.16	1846.66	2050x1060x1000
M60HL18	6.31	247	1,558.57	1607.07	1750x1060x1000
M60HL15	5.34	247	1,318.98	1367.48	1450x1060x1000
M60HL12	4.36	247	1,076.92	1125.42	1150x1060x1000
M60HL09	3.39	238	806.82	855.32	1060x1060x1000
M60HL06	2.42	512	1239.04	1287.54	1148x1148x820
M60HL03	1.45	600	870.00	954.00	1148x1148x820

Racking & Packing

Finelock M48 System Scaffold



■ Double Ledger

Part No.	Finelock M48 Components			Total Weight w/ Rack	Racking Dimension mm
	Weight (kg)	QTY/Rack (pcs)	Total weight (kg)		
M48DL30	18.72	88	1647.36	1695.86	2950x1060x1000
M48DL24	15.16	88	1334.08	1382.58	2350x1060x1000
M48DL21	13.15	88	1157.20	1205.70	2050x1060x1000
M48DL18	11.37	88	1000.56	1049.06	1750x1060x1000
M48DL15	9.35	88	822.80	871.30	1450x1060x1000

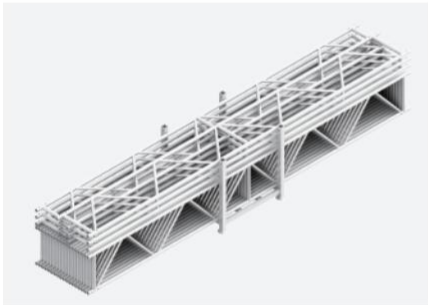

■ Aluminum Truss Beam

Part No.	Finelock M48 Components			Total Weight w/ Rack	Racking Dimension mm
	Weight (kg)	QTY/Rack (pcs)	Total weight (kg)		
ATB42	18.23	24	437.52	486.02	4200x1060x1000
ATB52	22.12	24	530.88	579.38	5200x1060x1000
ATB62	26.71	24	641.04	689.54	6200x1060x1000

■ Vertical Bay Brace

Part No.	Finelock M48 Components			Total Weight w/ Rack	Racking Dimension mm
	Weight (kg)	QTY/Rack (pcs)	Total weight (kg)		
M48VBB3020	10.19	198	2017.62	2066.12	3510x1060x100
M48VBB2420	9.03	198	1787.94	1836.44	3040x1060x1000
M48VBB2120	8.49	198	1681.02	1729.52	2820x1060x1000
M48VBB1820	8.00	198	1584.00	1632.50	2620x1060x1000
M48VBB1520	7.55	198	1494.90	1543.40	2440x1060x1000
M48VBB1220	7.17	198	1419.66	1468.16	2290x1060x1000
M48VBB0920	6.90	198	1366.20	1414.70	2170x1060x1000
M60VBB2415	8.26	198	1635.48	1683.98	2730x1060x1000
M60VBB2115	7.66	198	1516.68	1565.18	2490x1060x1000
M60VBB1815	7.09	198	1403.82	1452.32	2260x1060x1000
M60VBB1515	6.57	198	1300.86	1349.36	2050x1060x1000
M60VBB1215	6.11	198	1209.78	1258.28	1860x1060x1000
M60VBB0915	5.73	198	1134.54	1183.04	1710x1060x1000
M60VBB0615	5.46	198	1081.08	1129.58	1600x1060x1000

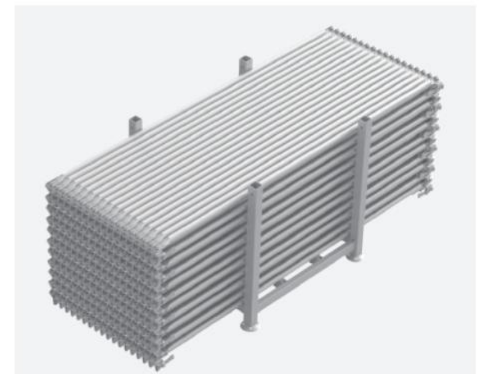

Racking & Packing

Finelock M48 System Scaffold

■ Side Bracket (M48)

Part No.	Finelock M48 Components			Total Weight w/ Rack	Racking Dimension mm
	Weight (kg)	QTY/Rack (pcs)	Total weight (kg)		
M48SB12	11.57	25	289.25	373.25	1148x1148x820
M48SB09	7.76	40	310.40	394.40	1148x1148x820
M48SB06	6.13	63	386.19	470.19	1148x1148x820
M48SB03	4.00	100	400.00	484.00	1148x1148x820



■ Base Jack (M48)

Part No.	Finelock M48 Components			Total Weight w/ Rack	Racking Dimension mm
	Weight (kg)	QTY/Rack (pcs)	Total weight (kg)		
M48ABJ	3.70	270	999.00	1083.00	1060x1060x1000



■ U-Head Jack (M48)

Part No.	Finelock M48 Components			Total Weight w/ Rack	Racking Dimension mm
	Weight (kg)	QTY/Rack (pcs)	Total weight (kg)		
M48AUH	4.80	180	864	948.00	1200x1200x1000

■ Steel Plank

Part No.	Finelock M48 Components			Total Weight w/ Rack	Racking Dimension mm
	Weight (kg)	QTY/Rack (pcs)	Total weight (kg)		
M48SP_30	17.72	72	1275.84	1324.34	3060x1060x1000
M48SP_24	14.42	72	1038.24	1086.74	2460x1060x1000
M48SP_21	12.76	72	918.72	967.22	2160x1060x1000
M48SP_18	11.11	72	799.92	848.42	1860x1060x1000
M48SP_15	9.46	72	681.12	729.62	1560x1060x1000
M48SP_12	7.80	72	561.60	610.10	1260x1060x1000
M48SP_09	6.15	72	442.80	491.30	1060x1060x1000
M48SP_06	4.50	72	324.00	372.50	1060x1060x1000



Racking & Packing

Finelock M48 System Scaffold

■ Steel WalkBoard



Part No.	Finelock M48 Components			Total Weight w/ Rack	Racking Dimension mm
	Weight (kg)	QTY/Rack (pcs)	Total weight (kg)		
M48SWB_30	18.90	65	1228.50	1277.00	3060x1060x1000
M48SWB_24	15.27	65	992.55	1041.05	2460x1060x1000
M48SWB_21	13.55	65	880.75	929.25	2160x1060x1000
M48SWB_18	11.72	65	761.80	810.30	1860x1060x1000
M48SWB_15	9.92	65	644.80	693.30	1560x1060x1000
M48SWB_12	8.17	65	531.05	579.55	1260x1060x1000
M48SWB_09	6.45	65	419.25	467.75	1060x1060x1000
M48SWB_06	4.81	65	312.65	361.15	1060x1060x1000

■ Access Walkboard

Part No.	Finelock M48 Components			Total Weight w/ Rack	Racking Dimension mm
	Weight (kg)	QTY/Rack (pcs)	Total weight (kg)		
M48AWB18_09	21.40	19	406.60	455.10	1860x1060x1000
M48AWB18_06	13.86	23	318.78	367.28	1860x1060x1000

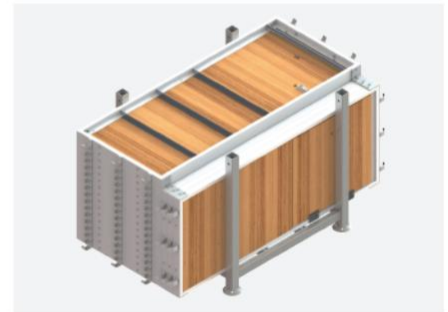

■ Steel Walkboard Filler

Part No.	Finelock M48 Components			Total Weight w/ Rack	Racking Dimension mm
	Weight (kg)	QTY/Rack (pcs)	Total weight (kg)		
M48SWBF30	10.00	400	4000.00	4048.50	2840x1060x1000
M48SWBF24	7.88	400	3152.00	3200.50	2240x1060x1000
M48SWBF21	6.83	400	2732.00	2780.50	1940x1060x1000
M48SWBF18	5.77	400	2308.00	2356.50	1640x1060x1000
M48SWBF15	4.72	400	1888.00	1936.50	1340x1060x1000
M48SWBF12	3.66	400	1464.00	1512.50	1040x1060x1000
M48SWBF09	2.60	500	1300.00	1384.00	1148x1148x820
M48SWBF06	1.55	500	775.00	859.00	1148x1148x820

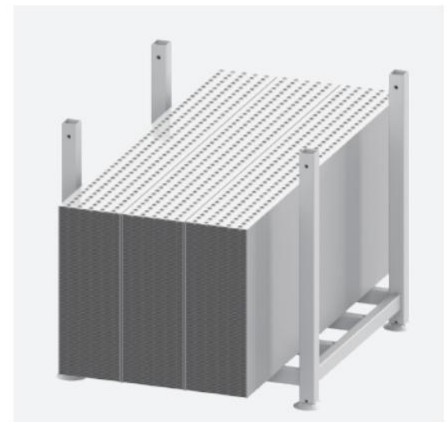

■ Spigot (M48)

Part No.	Finelock M48 Components			Total Weight w/ Rack	Racking Dimension mm
	Weight (kg)	QTY/Rack (pcs)	Total weight (kg)		
M48S	0.40	1000	400	484.00	1148x1148x820

Racking & Packing

Finelock M48 System Scaffold

■ Toeboard

Part No.	Finelock M48 Components			Total Weight w/ Rack	Racking Dimension mm
	Weight (kg)	QTY/Rack (pcs)	Total weight (kg)		
M48TB30	9.93	320	3177.60	3226.10	3050x1060x1000
M48TB24	7.96	320	2547.20	2595.70	2450x1060x1000
M48TB21	6.98	320	2233.60	2282.10	2150x1060x1000
M48TB18	6.00	320	1920.00	1968.50	1850x1060x1000
M48TB15	5.02	320	1606.40	1654.90	1550x1060x1000
M48TB12	4.03	320	1289.60	1338.10	1250x1060x1000
M48TB09	3.05	320	976.00	1024.50	1550x1060x1000
M48TB06	2.07	400	828.00	876.50	1200x1200x1000



■ Access Ladder

Part No.	Finelock M48 Components			Total Weight w/ Rack	Racking Dimension mm
	Weight (kg)	QTY/Rack (pcs)	Total weight (kg)		
M48AL21	8.09	32	258.88	307.38	2150x1060x1000
M48AL15	5.83	32	186.56	235.06	1600x1060x1000



■ Scaffold Ladder

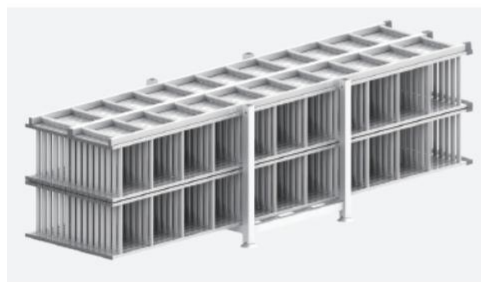

Part No.	Finelock M48 Components			Total Weight w/ Rack	Racking Dimension mm
	Weight (kg)	QTY/Rack (pcs)	Total weight (kg)		
M48ASL65	16.90	32	540.80	589.30	6500x1060x1000
M48ASL55	14.30	32	457.60	506.10	5500x1060x1000
M48ASL45	11.90	32	380.80	429.30	4500x1060x1000
M48ASL35	9.40	32	300.80	349.30	3500x1060x1000
M48SSL65	38.01	32	1216.32	1264.82	6500x1060x1000
M48SSL55	31.90	32	1020.80	1069.30	5500x1060x1000
M48SSL45	26.23	32	839.36	887.86	4500x1060x1000
M48SSL35	20.57	32	658.24	706.74	3500x1060x1000



■ Stairway Aluminum

Part No.	Finelock M48 Components			Total Weight w/ Rack	Racking Dimension mm
	Weight (kg)	QTY/Rack (pcs)	Total weight (kg)		
M60SW2420_AL650	22.59	8	180.72	229.22	3210x1060x1000
M60SW2120_AL650	22.68	8	181.44	229.94	2980x1060x1000
M60SW1820_AL650	20.84	8	166.72	215.22	2780x1060x1000

Racking & Packing

Finelock M48 System Scaffold

■ Platform Stairway Aluminum

Part No.	Finelock M48 Components			Total Weight w/ Rack	Racking Dimension mm
	Weight (kg)	QTY/Rack (pcs)	Total weight (kg)		
M48PSW3020_AL750	33.47	6	200.82	249.32	3690x1060x1000
M48PSW2420_AL750	29.11	6	174.66	223.16	3200x1060x1000

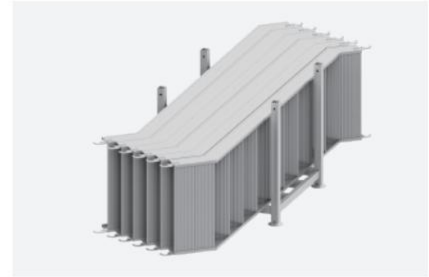

■ Aluminum Scaffolders Step

Part No.	Finelock M48 Components			Total Weight w/ Rack	Racking Dimension mm
	Weight (kg)	QTY/Rack (pcs)	Total weight (kg)		
M48ASS	5.94	18	106.92	155.42	1060x1060x1000

■ Suspended Standard Clamp

Part No.	Finelock M48 Components			Total Weight w/ Rack	Racking Dimension mm
	Weight (kg)	QTY/Rack (pcs)	Total weight (kg)		
M48SSC	8.84	80	707.20	791.20	1148x1148x820



■ Beam Side Clamp

Part No.	Finelock M48 Components			Total Weight w/ Rack	Racking Dimension mm
	Weight (kg)	QTY/Rack (pcs)	Total weight (kg)		
M48BSC	6.95	80	556.00	640.00	1148x1148x820



■ Cantilever Clamp

Part No.	Finelock M48 Components			Total Weight w/ Rack	Racking Dimension mm
	Weight (kg)	QTY/Rack (pcs)	Total weight (kg)		
M48CC	9.81	80	784.80	868.80	1148x1148x820



Racking & Packing

Finelock M48 System Scaffold

■ Transom

Part No.	Finelock M48 Components			Total Weight w/ Rack	Racking Dimension mm
	Weight (kg)	QTY/Rack (pcs)	Total weight (kg)		
M48TLL24	9.37	154	1442.98	1491.48	2460x1060x1000
M48TLL21	8.31	154	1279.74	1328.24	2160x1060x1000
M48TLL18	7.25	154	1116.50	1165.00	1860x1060x1000
M48TLL15	6.19	154	953.26	1001.76	1560x1060x1000
M48TLL12	5.13	154	790.02	838.52	1260x1060x1000
M48TLL09	4.04	154	622.16	670.66	1060x1060x1000
M48TBB75	4.21	154	648.34	732.34	1148x1148x820
M48TBB50	3.37	150	505.50	589.50	1148x1148x820
M48TBB25	2.52	300	756.00	840.00	1148x1148x820
M48TLB75	3.98	154	612.92	696.92	1148x1148x820
M48TLB50	3.17	150	475.50	559.50	1148x1148x820
M48TLB25	2.36	300	708.00	792.00	1148x1148x820



■ Rosette Wedge Coupler



Part No.	Finelock M48 Components			Total Weight w/ Rack	Racking Dimension mm
	Weight (kg)	QTY/Rack (pcs)	Total weight (kg)		
M48RWC	1.25	1000	1,250.00	1334.00	1148x1148x820

■ Transom Clamp

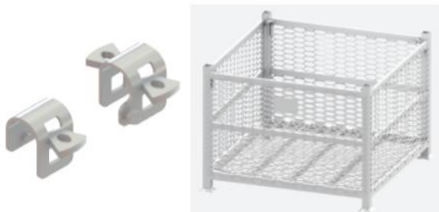

Part No.	Finelock M48 Components			Total Weight w/ Rack	Racking Dimension mm
	Weight (kg)	QTY/Rack (pcs)	Total weight (kg)		
M48TC-S	0.48	2000	960.00	1044.00	1148x1148x820
M48TC-D	0.57	2000	1140.00	1224.00	1148x1148x820

■ Adjustable Swing Gate

Part No.	Finelock M48 Components			Total Weight w/ Rack	Racking Dimension mm
	Weight (kg)	QTY/Rack (pcs)	Total weight (kg)		
M48AGD	11.07	16	177.12	261.12	1148x1148x820



■ Access Trap Door

Part No.	Finelock M48 Components			Total Weight w/ Rack	Racking Dimension mm
	Weight (kg)	QTY/Rack (pcs)	Total weight (kg)		
M48ATD	14.23	20	284.60	368.60	1148x1148x820



Racking & Packing

Finelock M48 System Scaffold



■ Corner Deck

Part No.	Finelock M48 Components			Total Weight w/ Rack	Racking Dimension mm
	Weight (kg)	QTY/Rack (pcs)	Total weight (kg)		
M48CD	10.69	80	855.20	939.20	1148x1148x820



■ Corner Deck Adaptor

Part No.	Finelock M48 Components			Total Weight w/ Rack	Racking Dimension mm
	Weight (kg)	QTY/Rack (pcs)	Total weight (kg)		
M48CDA	3.04	300	912.00	996.00	1148x1148x820

■ Spigot Clamp

Part No.	Finelock M48 Components			Total Weight w/ Rack	Racking Dimension mm
	Weight (kg)	QTY/Rack (pcs)	Total weight (kg)		
M48SC	1.46	600	876.00	960.00	1148x1148x820



■ Platform Stairway Post

Part No.	Finelock M48 Components			Total Weight w/ Rack	Racking Dimension mm
	Weight (kg)	QTY/Rack (pcs)	Total weight (kg)		
M48PSP	5.79	110	636.90	685.40	1150x1060x1000

■ Wedge-Head Coupler

Part No.	Finelock M48 Components			Total Weight w/ Rack	Racking Dimension mm
	Weight (kg)	QTY/Rack (pcs)	Total weight (kg)		
M48WHC_D	0.96	800	768.00	852.00	1148x1148x820
M48WHC_H	1.07	800	856.00	940.00	1148x1148x820
M48WHC_V	1.07	800	856.00	940.00	1148x1148x820
M48WHC_S	1.26	800	1008.00	1092.00	1148x1148x820

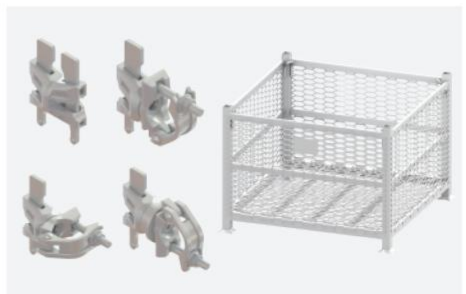

Finelock M48 System Scaffold

Civil, Infrastructure and Industrial Applications

Finelock M48 is not only widely used in construction and infrastructure projects, but also in a variety of industrial projects such as oil & gas, chemical plants, shipbuilding etc, as well as temporary facilities for sports and events. Finelock M48 has been designed and prefabricated with various special components, greatly improving the safety and efficiency of these special applications.





Special Designed Components For High Safety Standards



V01-092024

Headquarter

Wenma Forming and Shoring Co., Ltd.
E2-16, Binhai International Business Park
199 Haiyuan Road, Binhai New Area,
Tianjin 300451, P.R. of China
+86-22-25646163
info@iwenma.cn
www.iwenma.cn

Wenma Scaffolding Solutions Co., Ltd.
E2-16, Binhai International Business Park,
199 Haiyuan Road, Binhai New Area,
Tianjin 300451, P.R. of China
+86-22-25646163
info@iwenma.com
www.iwenma.com

Hong Kong, China

Wenma Scaffolding Solutions Hong Kong Limited
Room 06, 13A/F., South Tower, World Finance
Centre, Harbor City, 17 Canton Road, Tsim Sha Tsui,
Kowloon, Hong Kong
info@iwenma.com
www.iwenma.com

Hong Kong, China

Wenma Forming & Scaffolding (H.K.) Limited
UNIT11, 16/F, METROPOLE SQUARE, NO. 2 ON
YIU STREET, SHATIN, N.T. HONG KONG
+852-9199-9158
info@iwenma.com
www.iwenma.com

Qatar

Wenma Scaffolding Solutions and Services W.L.L.
Regus, Doha Bank Street, Office 201,
Blue Tower, Sword Signal, Bank Street
PO Box 55918, Doha, Qatar
info@iwenma.com www.iwenma.com

Saudi Arabia

Wenma Scaffolding Co., Ltd.
Building 4294, Al khaliq Rd, 7943 Az Zhuhur Dist.,
32423 Office 12 Dammam city, Saudi Arabia
info@iwenma.com www.iwenma.com

Malaysia

Wenma Scaffolding Solutions And Services (M) SDN BHD
A-23-12, The MET Corporate Towers, 20 Jalan
Dutamas 250480 Kuala Lumpur, Malaysia
info@iwenma.com www.iwenma.com